

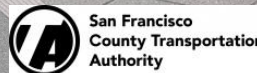

SFCTA
Board Meeting
5/24/2022



Phase 1 Schedule

**Spring 2022:
Contract Awarded**

**Summer 2022:
Construction
Mobilization &
Outreach**

**Fall 2022:
Groundbreaking**

**Winter 2024:
Construction
Complete**

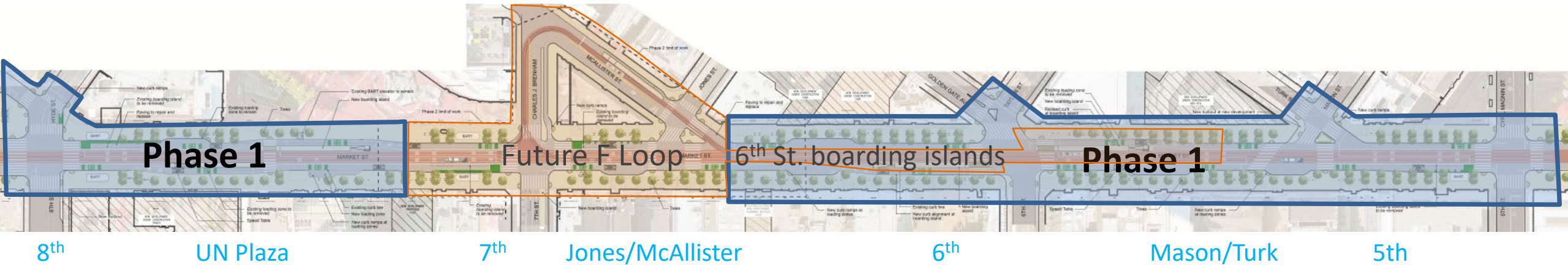

- **Five traffic signal upgrades**
- **Repave** curb lane and intersections, including crosswalks
- Construct ADA-compliant **curb ramps**
- Construct **four bulb outs** at Sixth, Hyde, and Mason/Turk
- **Replace sidewalks** at the corners
- **Streetscape improvements** including new trees, benches and bike racks

Utility work:

- **Install four catch basins** near 6th to improve drainage
- **Minimal sewer work** triggered by curb ramp and regrading work
- **Relocate one** low pressure fire hydrant for sidewalk widening
- **Minimal Auxiliary Water Supply System (AWSS)** work at Market/6th St triggered by bulb out
- **Minimal Overhead Contact System (OCS) work** triggered by joint OCS / traffic signal poles



Platanus
(London Plane)



Ulmus
(Chinese Elm)



Lophostemon
(Brisbane Box)



Concrete Pavers



Bike Racks

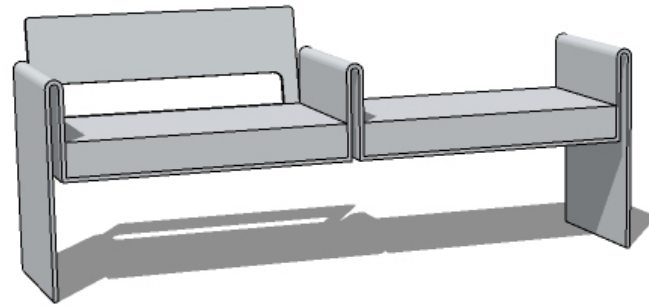

Seating

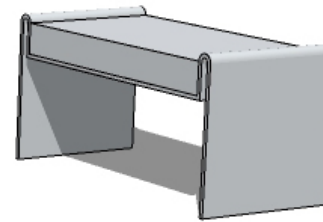

Better Market Street Funding Plan (\$M)



Funding Source	Corridor Env. & 30% Design	Design	Phase 1 Redesign	Construction	Future Phases	Total
General Fund	5.16					5.16
Octavia Land Sales	3.05					3.05
Market Octavia Impact Fees	1.50					1.50
Transit Center Impact Fees					2.00	2.00
Prop A GO Bond	12.96	7.64	7.00	30.30	68.37	126.27
SFMTA Transit Funds		1.36				1.36
Prop K		2.23		5.48	6.16	13.87
BUILD				15.00		15.00
OBAG				3.37		3.37
Repurposed Federal Earmark				.07		.07
AHSC Grant				2.70		2.70
BART (8th/Grove/Hyde/Market)		.23		.62		.85
FY22 COP				3.00		3.00
PUC		2.10			22.16	24.26
Total Identified Funding	22.67	13.56	7.00	60.54	98.69	202.46

Bike Accommodations during Construction

Weekdays

7' bike space maintained in peak directions to accommodate rush hour trips (see graphs)

Saturdays:

No bike access (both sides) 7am – 7pm

No bike accommodations on Market during the three two-week full closures

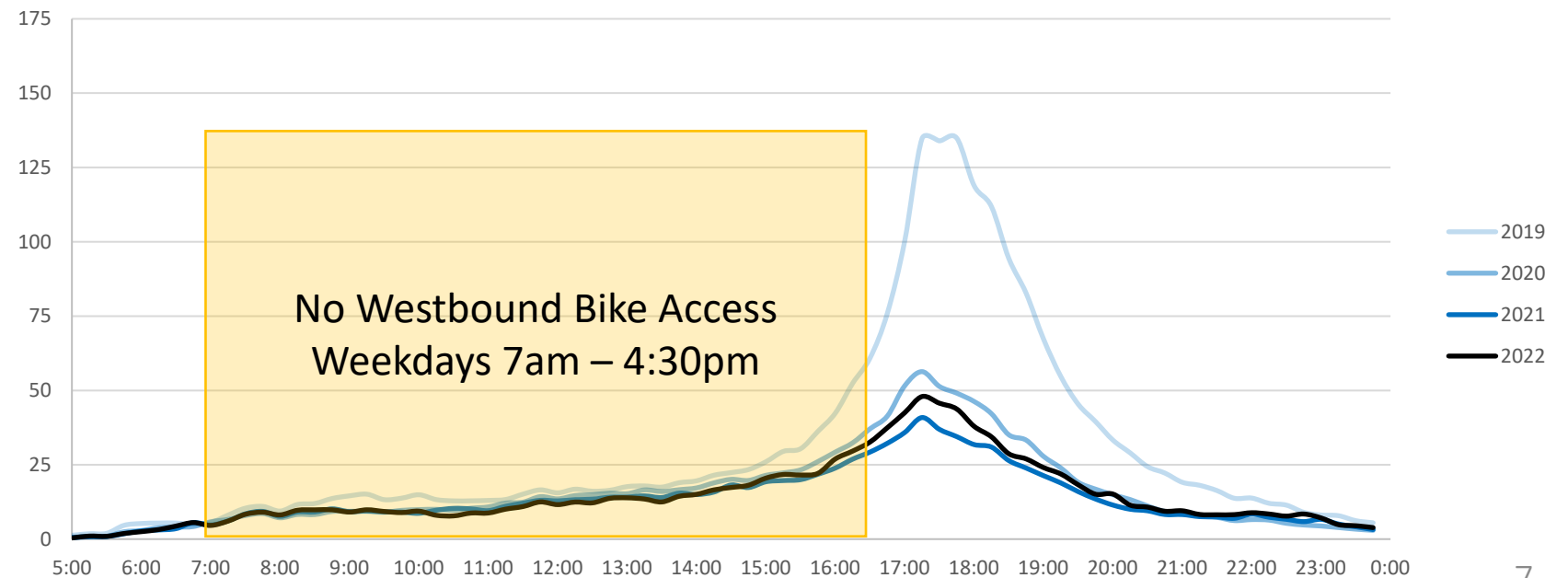
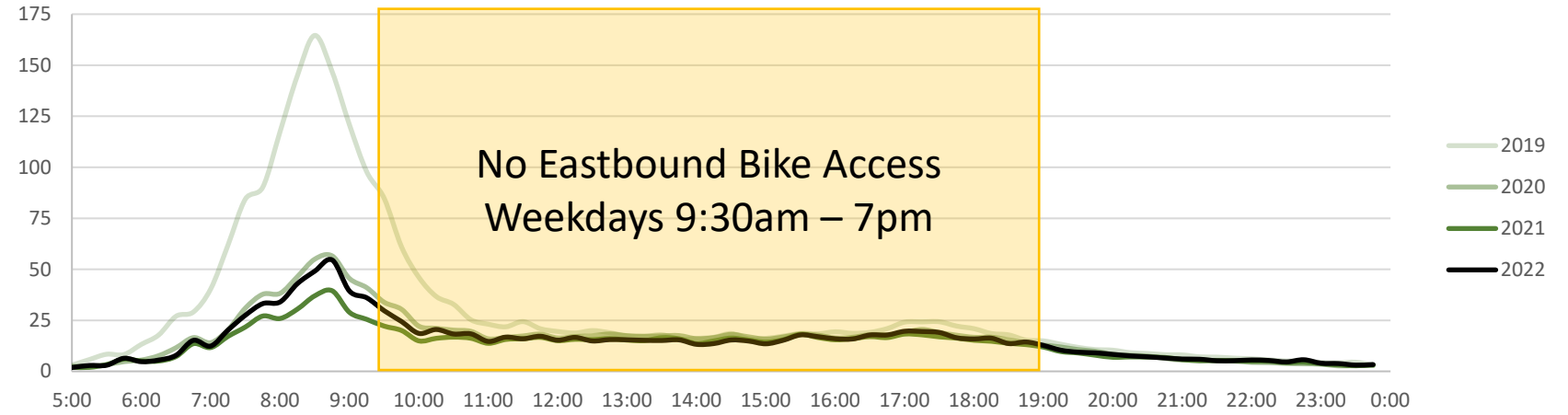

Average Weekday Bike Volumes (15 min. Intervals)
Market Street, between 9th and 10th streets

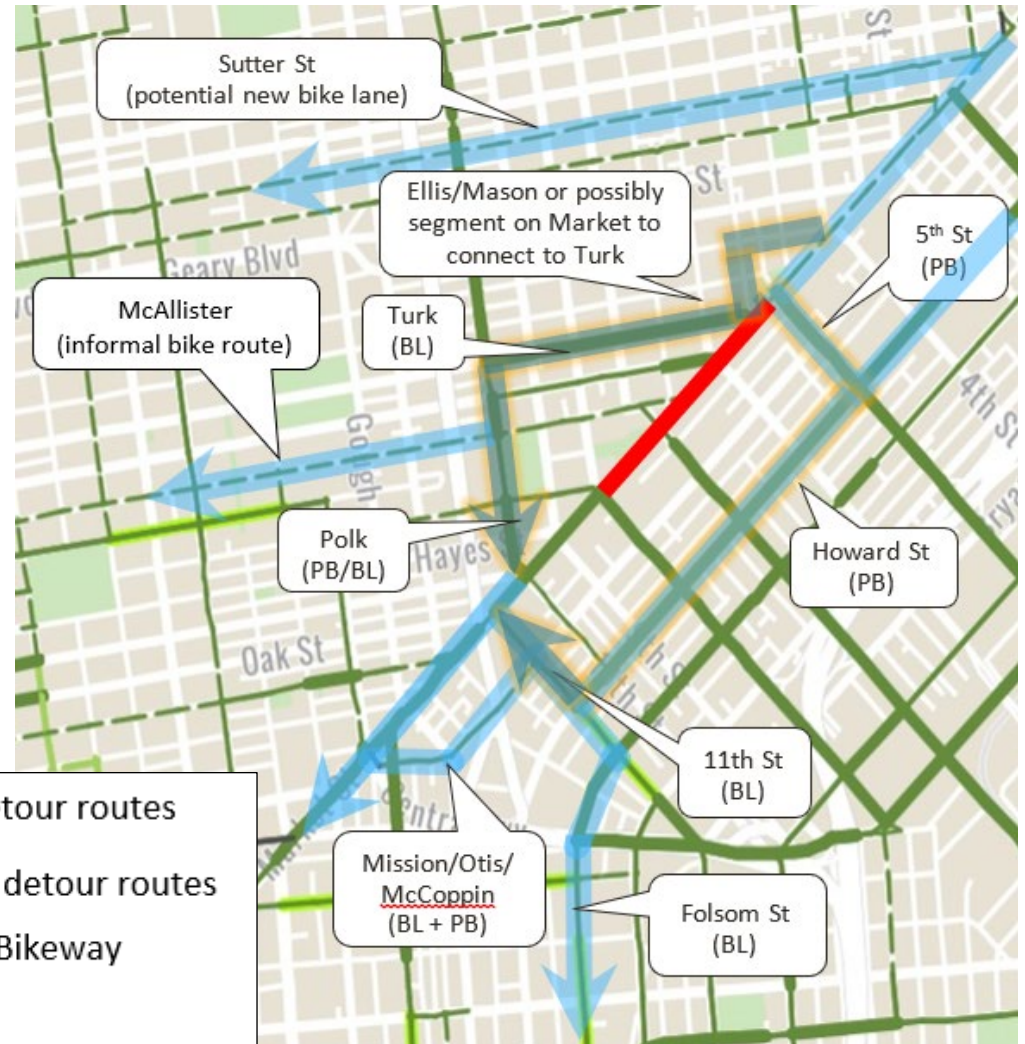
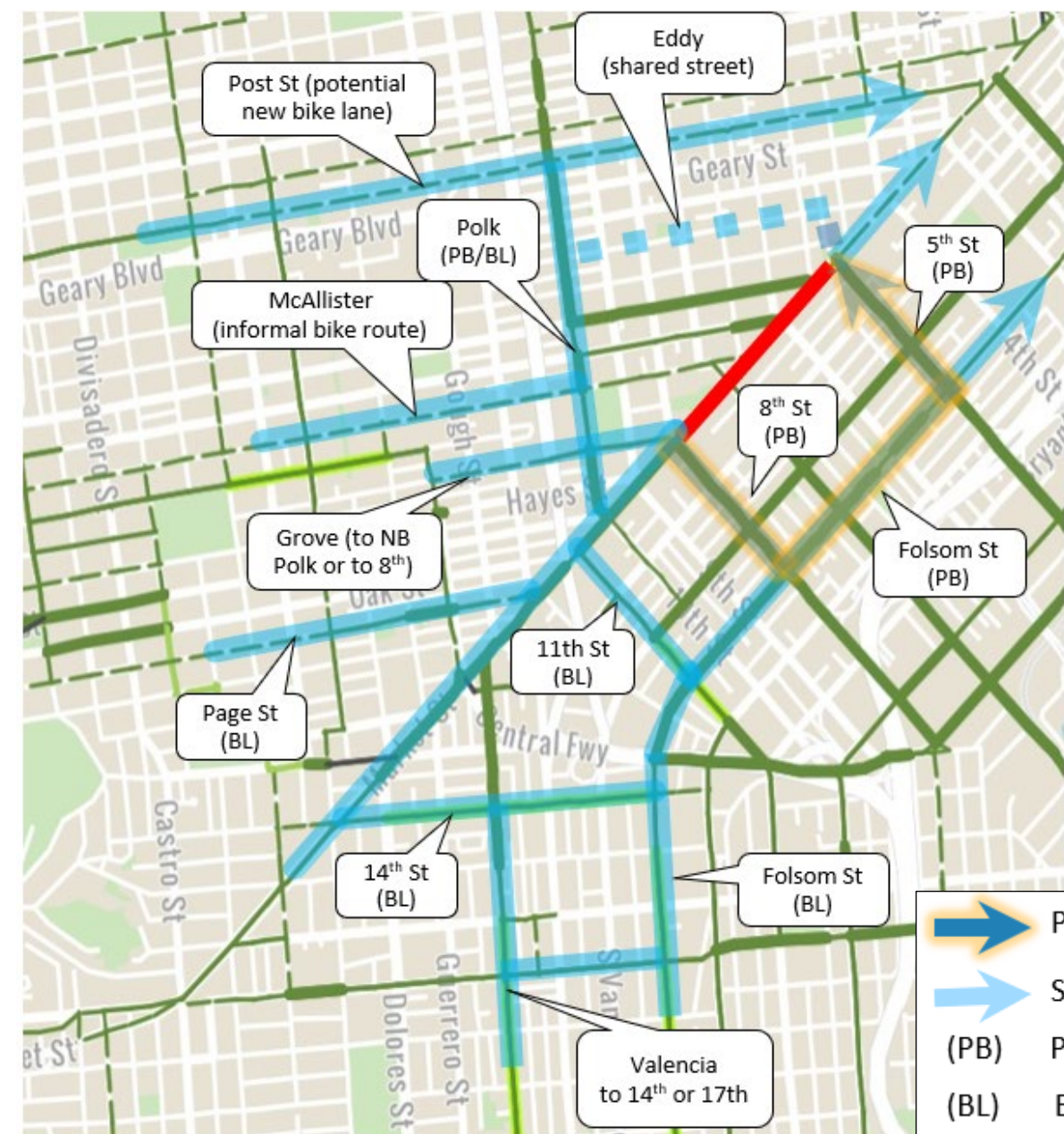

Bike Routing During Construction

Eastbound detour adds 5 minutes (0.7 mile) via Folsom
 Westbound detour adds 4-5 minutes (0.3-0.5 miles) via Howard or Turk/Polk



-  Primary detour routes
-  Secondary detour routes
- (PB) Protected Bikeway
- (BL) Bike Lane



OEWD Construction Mitigation Better Market Street



SAN FRANCISCO
OFFICE OF ECONOMIC &
WORKFORCE DEVELOPMENT

May 24, 2022

OEWD Construction Mitigation Business Services Offered to Merchants

- An MOU was signed in 2018 by SFMTA, DPW, SFPUC and OEWD to create the partnership that adds a business support services component to selected construction projects.
- The objective of the business support component led by OEWD's Invest In Neighborhoods (IIN) Division is to support business owners as they navigate through construction projects.
- IIN will serve as a business liaison and point of contact for business support services, including
 - technical assistance
 - corridor specific-marketing campaign (Open For Business)
 - business support
 - Directed Business Support grant program when applicable
- This suite of services has been put together to support both the short-term and longer-term needs of businesses and some of these are available to impacted zones when determined and funded by the lead project department.

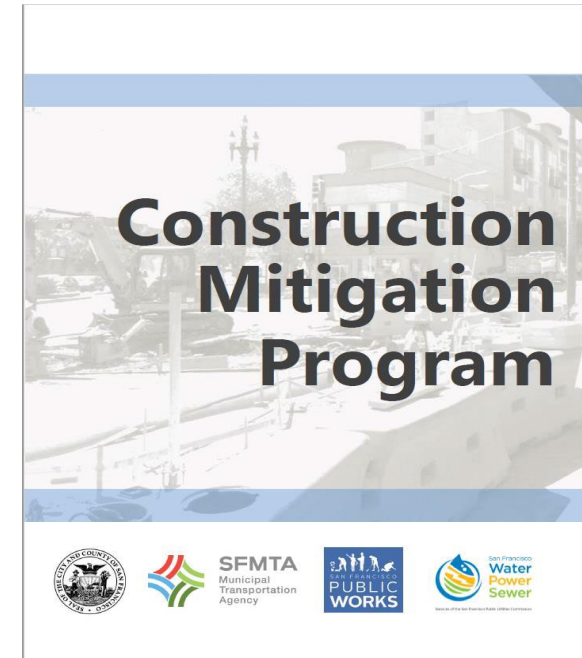

OEWD Construction Mitigation Business Support Services

The OEWD Business Liaison has the responsibility to continue strengthening efforts pertaining to construction mitigation with our partner agencies, other City agencies and merchants to:

- Take a proactive approach with wraparound services for merchants preconstruction through post construction.
- Provide business education by leveraging resources.
- Maintain an active presence as a member of the project team.

OEWD Construction Mitigation Business Support Services

OEWD, with support of the Small Business Development Center (SBDC) provides Technical Assistance to small businesses; key elements include:

- Paired with small business advisor
- Develop an Action Plan
- Evaluation and ongoing support

OEWD also provides business education and leverages other programs and services available to small businesses such as its

- Legacy Business Program
- Small Business Revolving Loan Fund
- San Francisco Women's Entrepreneurship Fund

OEWD Construction Mitigation Business Support Services

Businesses will be able to access for free the expertise of the San Francisco Small Business Development Center, (SBDC) for training and one-on-one consulting in a variety of areas such as:

- Business Accounting/Budgeting
- Cash Flow Management
- e-Commerce
- Financing/Capital
- HR/Managing Employees
- Lease Negotiations
- Legal Issues
- Social Media
- Tax Planning
- Technology
- Training

OEWD Construction Mitigation Corridor-Specific Marketing Campaign

- The Open for Business Program (OFB) provides direct marketing support based on the unique identity to attract residents, visitors and customers to neighborhoods undergoing moderate-impact to major-impact construction projects in San Francisco reminding people that this corridor is still open for business while improvements are taking place.
- OFB works in close coordination with merchants. For the Better Market Street project a small business Working Group has been created to help guide program direction and priorities for this corridor.
- A small business merchant survey was provided to small businesses in the identified construction zone.

Why outreach was conducted for the Small Business Merchant Survey

- To develop a connection with merchants in the Mid-Market Street area in the construction impact zone.
- To share information about small business support services that OEWD offers.
- To invite participants to join the Better Market Street Working Group to help direct the Open For Business Marketing campaign.

Types of outreach attempted



Ambassadors attempted in-person outreach twice

In-person outreach was conducted in English, Spanish, Cantonese, and Filipino



If ambassadors did not get in touch with merchants in-person, they followed up via phone call and/or email to reach businesses operating remotely or with limited hours



Outreach by the numbers



OEWD Construction Mitigation Next Steps

- Door-to-door outreach to businesses in the construction impact zone providing a Resource Guide that details resources available for small businesses with project information and contact information.
- OEWD will continue to inform small businesses of programs and resources available and will connect businesses directly to City programs.
- Outreach will take place early June 2022.
- Engagement with the Better Market Street Working Group will continue for a robust marketing campaign.

THANK YOU

For programs and resources geared towards supporting small businesses visit:

www.oewd.org

Jada Jackson, Project Manager

OEWD Construction Mitigation Program

Jada.Jackson@sfgov.org | 415-554-6477