



SFMTA

A photograph of a white and red light rail train (LRV) on tracks in San Francisco. The train is numbered 2021A and has the SFMTA logo on its side. In the background, there are palm trees, streetlights, and the San Francisco City Hall building under a cloudy sky. A sign on the left reads 'NO HOV 3+ ENTER EXCEPT TAXICABS'. A sign on the right reads 'PORT The City's Connection to the Bay'.

# LRV4 Project Update

SFCTA CAC Meeting  
February 26, 2020

# LRV4 Reliability Program

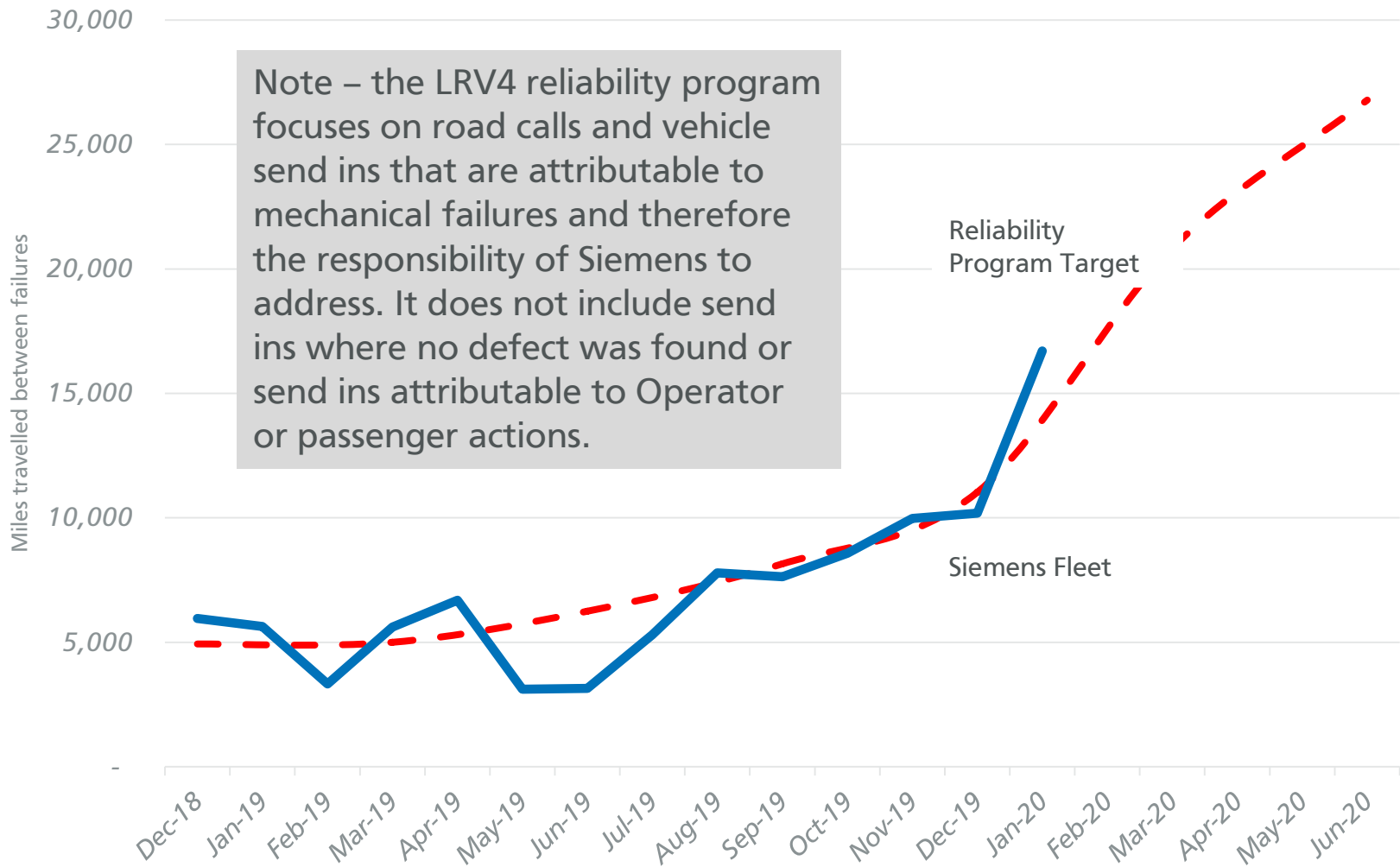

January figures are preliminary and subject to change

# In Service Breakdowns - Warranty Items

Issue	Count	Status	Comment
Hydraulic Power Unit Failure (brake system)	59	✓	All revenue cars modified
CCTV Failure	16		Software upgrade under evaluation
Loose Wire Termination	15	✓	Known issues fixed
Cameras (water intrusion)	14	✓	Cameras on all cars modified
Step Extension/ Gap Filler	10	✓	Adjustments complete
Misaligned doors	9		Door adjustment demo in process
Propulsion	9	✓	Addressed with latest software
Auxiliary Power Supply (APS) Reliability	8	✓	Modification complete
Pantograph	7	✓	Inaccurate fault warning - software fix
Brake Control Unit	5		Evaluation underway to determine if individual incidents are related

Note: other key issues addressed under warranty include installation of additional door sensitive edges and redesigned coupler end stop.

# LRV4 Monthly Mileage

Improved vehicle availability enabled LRV4 service to **double** in 2019

## Mileage

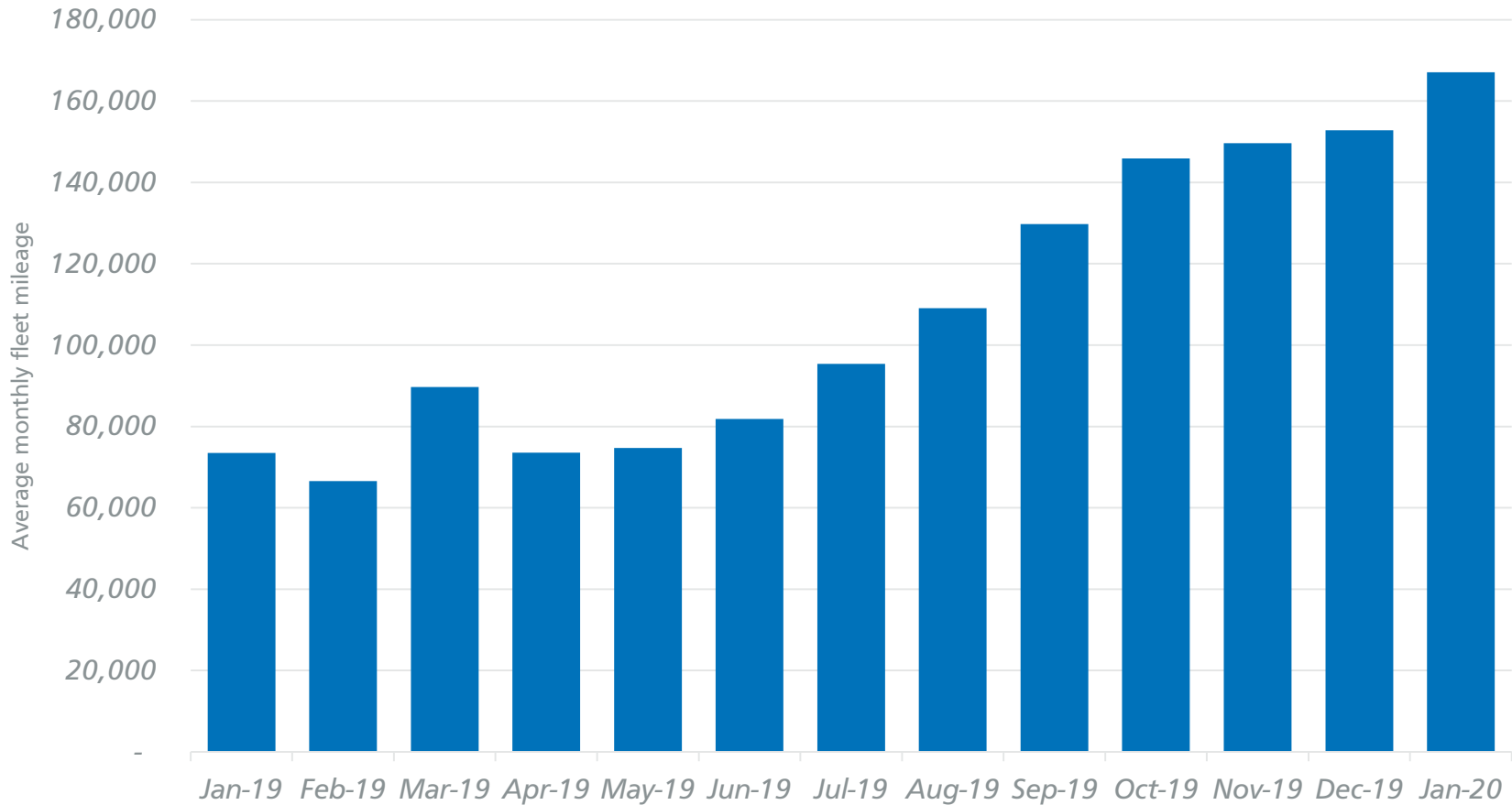

# LRV4 Fleet Availability

## Availability

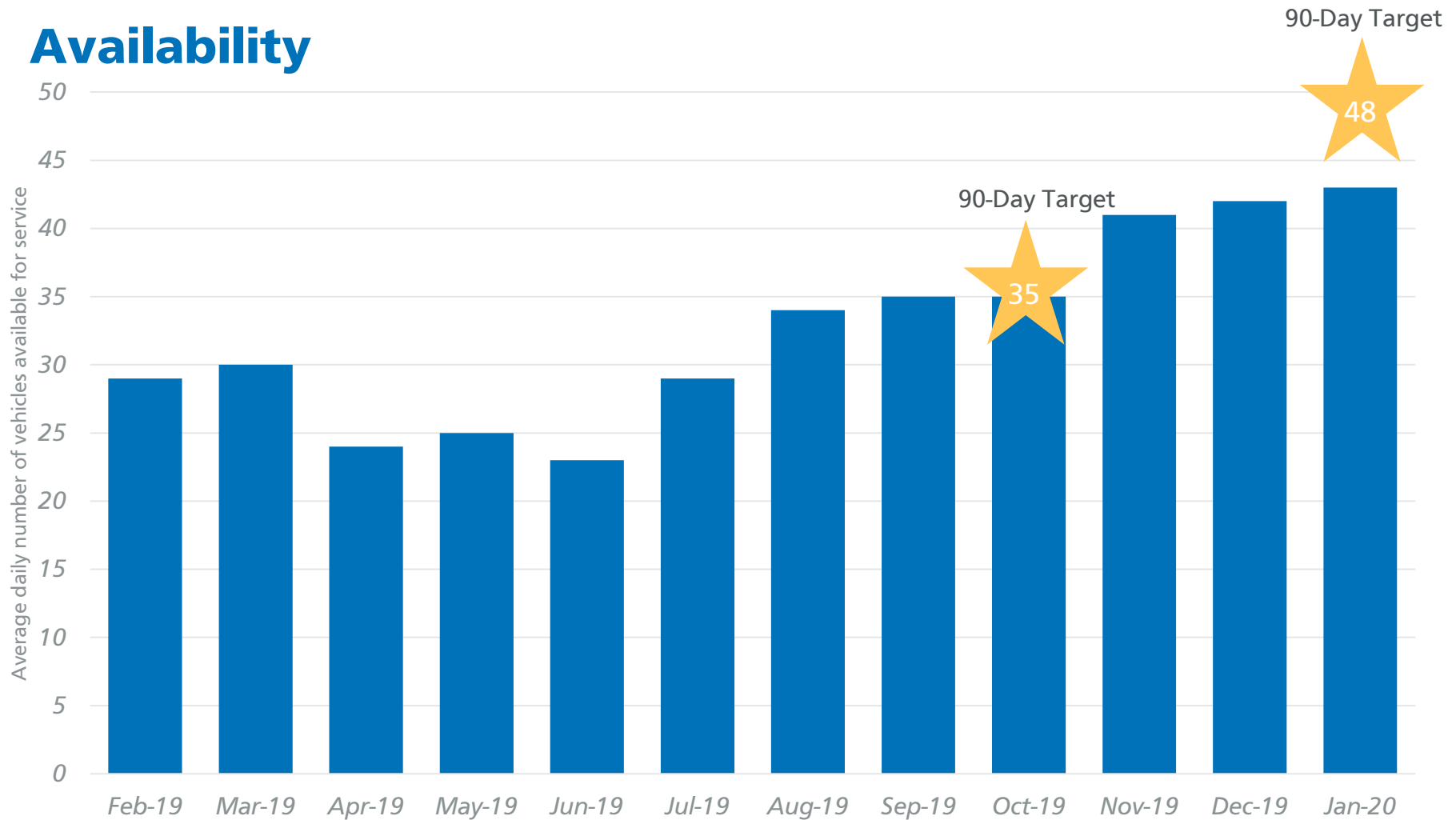

# Next steps for availability

- Purchase remaining 3 cars:
  - Original test cars (2001, 2003) getting latest configuration (spring)
  - Car 2033 on property, but heavily borrowed from to keep other vehicles in service (summer)
- Replace minimum diameter wheels on 6 trains (at least 1 per month)
- Eliminate flat wheels - 51 Vehicles have had additional track brakes installed, expected completion in March

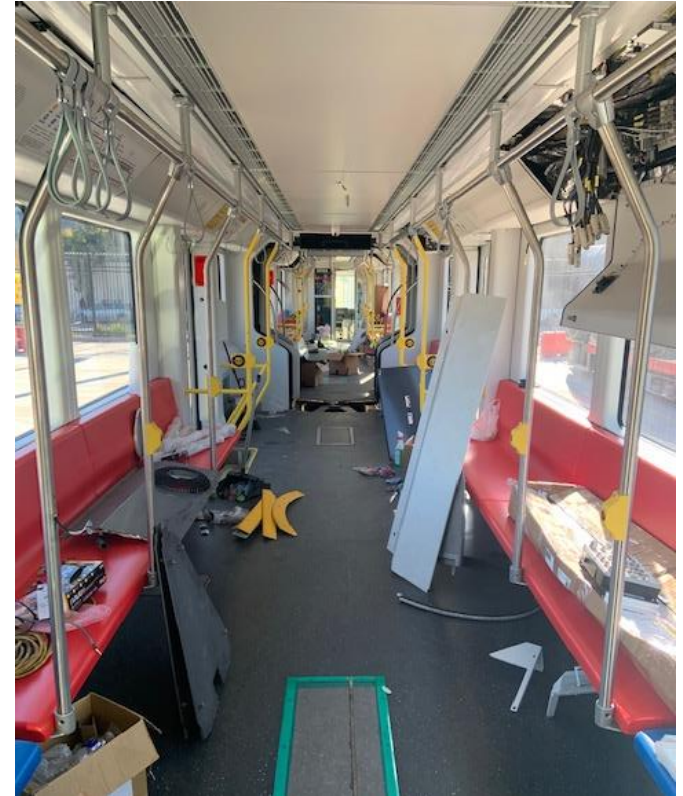

*Train 2033 has not been purchased but is at SFMTA; parts have been borrowed from this train to keep others in service - all parts will be restored this Summer*

# Shear pin update

- Dec 11: Shear pins failed in service, two-car operations was restricted
- Dec 23: All shear pins replaced, two-car operations resumes without restrictions (pins will continue to be replaced every 90 days)
- Jan 2020: Data gathering completed, primary cause is sudden change of gradient at intersections
- Feb 2020: Full evaluation of data and redesign to address issue underway
- All costs covered by Siemens under warranty



# Shear pin diagram

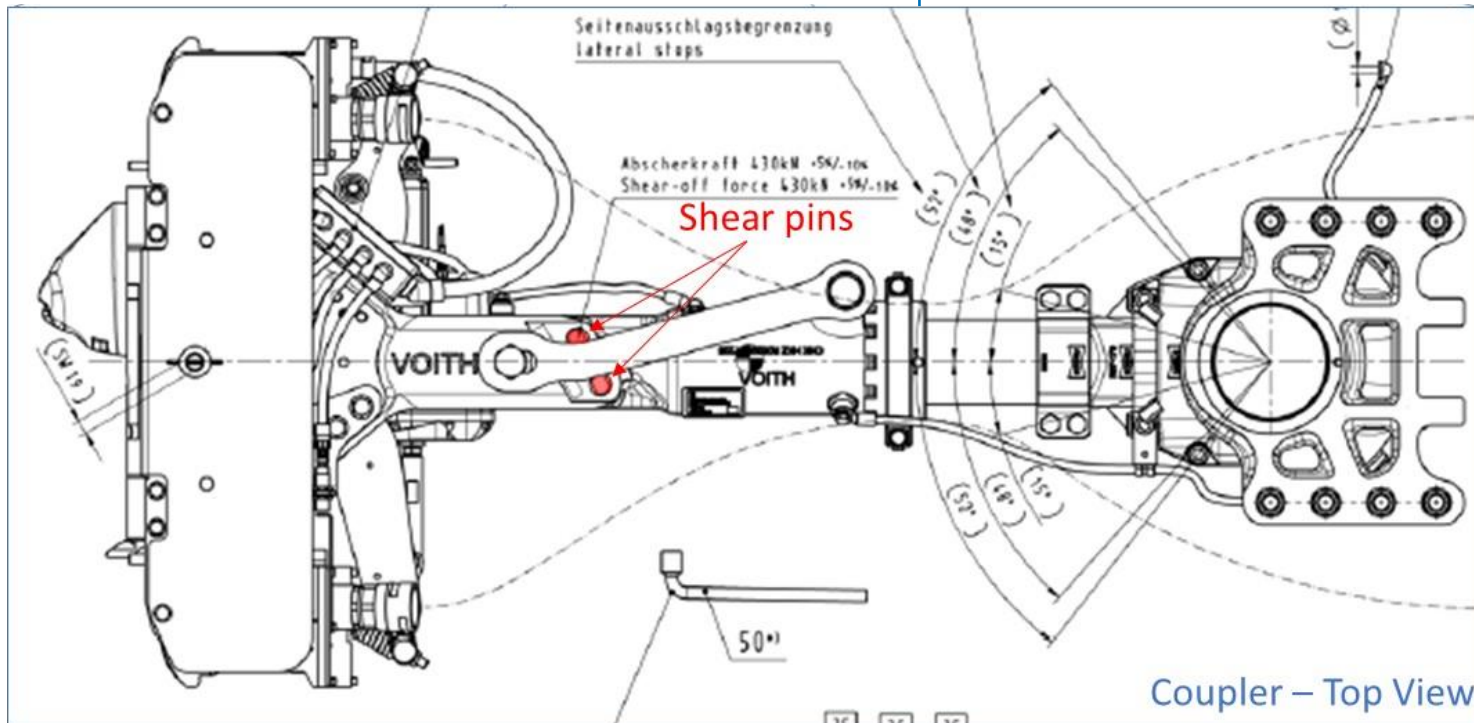
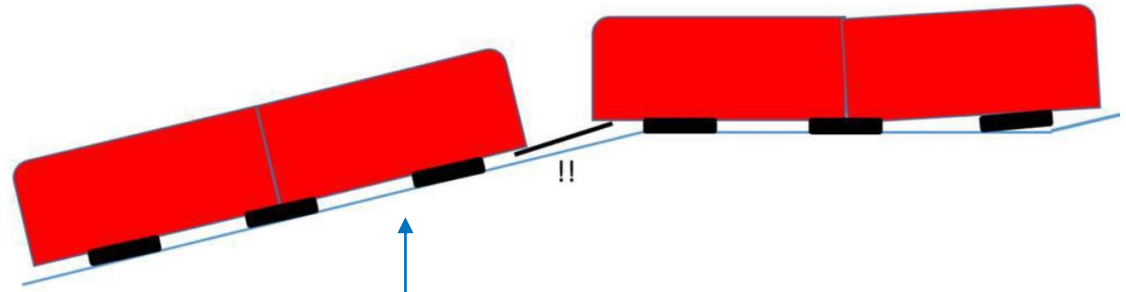



# Seat modification design underway

<b>FLEET</b>	<b>INTERIOR DESIGN MODIFICATION</b>
50 replacement	Convert half of longitudinal seats to single transverse
101 replacement	Convert half of longitudinal seats to double transverse
68 expansion	Retrofit bench seating style to individual seats, convert half of longitudinal seats to single transverse

# Seating Arrangement – Single



*More blue seats will be added based on customer feedback*

# Seating Arrangement - Plan view, single seats

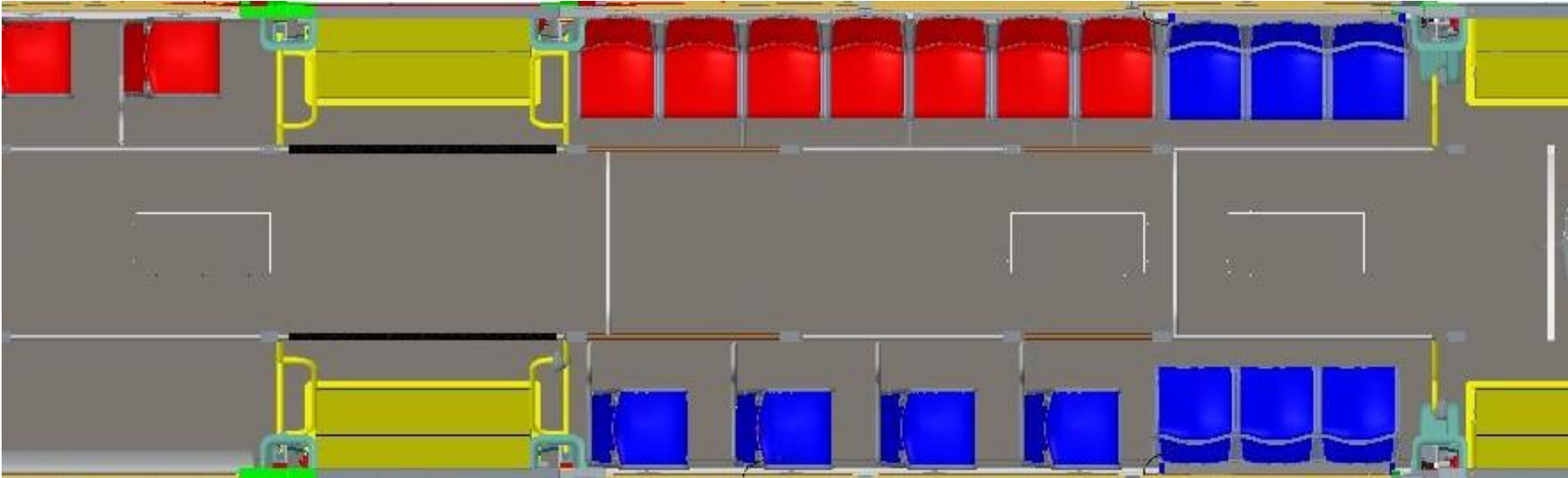

# Seating Arrangement - Double



*More blue seats will be added based on customer feedback*



# Seating Arrangement - Plan view, double seats

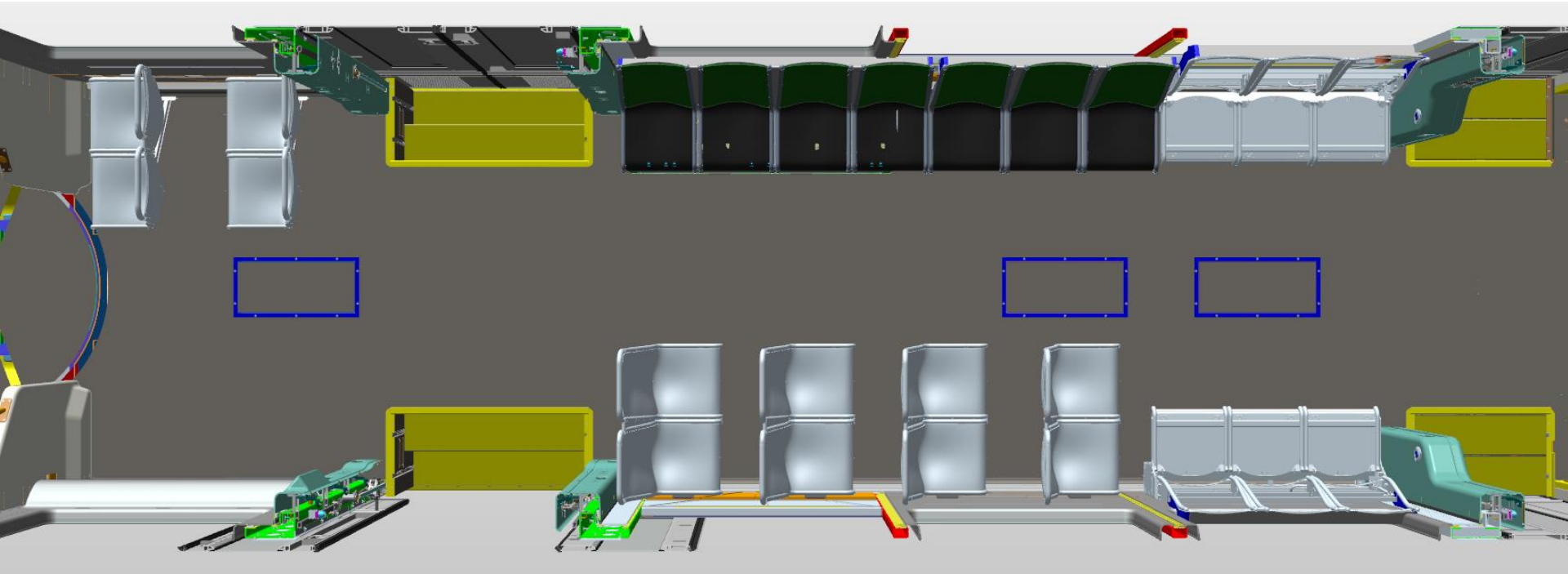

# Next Steps

- Request Prop K sales tax funding from SFCTA Board
- Initiate Contract Mod 7 for Phase 2 Breda replacement
- Re-design coupler to address shear pin issue
- Complete track brake installation end of March
- Accept remaining 3 cars and replace minimum diameter wheels on 6 cars
- Work with Operators to upgrade monitors



*Track brake highlighted in purple. Additional track brakes are being installed on the front and back of the train to reduce flat wheels and improve vehicle availability*

# Mod 6 and 7 Overview

Phase 1 lessons learned, including feedback from customers, operators and mechanics will be incorporated into Phase 2

- Breda early retirement (offsite car shell production) \$25M
- Seating changes (Phase 1, 2) \$18M
- Track brakes (Phase 1, 2) \$5M
- Additional Phase 2 changes \$5M

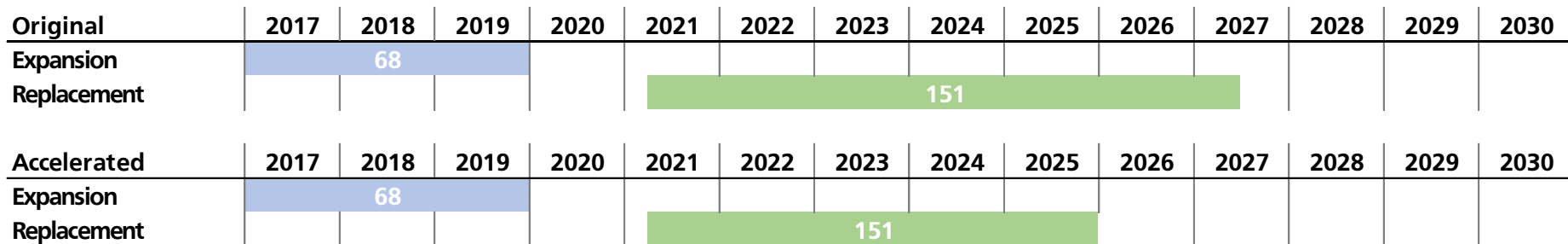



# Contract Mod. 7 Items

Update	Description	Team
Track Brakes Installation, Phase 2	Adding track brakes to all 151 Phase 2 vehicles to alleviate flat wheels.	Maintenance
Implementation of Interior Seating – Phase 1 Single Transverse	Seat changes, retrofits 68 Phase 1 vehicles with single transverse seating and related reconfigurations.	Passenger
Implementation of Interior Seating – Phase 2 Single Transverse	Seat changes, production of first 50 Phase 2 vehicles with single transverse seating and related reconfigurations.	Passenger
Implementation of Interior Seating – Phase 2 Double Transverse	Seat changes, production for 101 Phase 2 vehicles with double transverse seating and related reconfigurations.	Passenger
Lockable Convenience Outlet	A lockable cover will be added to the convenience outlet for all 219 Vehicles.	Operations/ Maintenance

# Contract Mod. 7 Items (cont'd.)

Update	Description	Team
Televic Passenger Information System change items	Multiple Passenger Information System (PIS) enhancements to update the technology consistent with evolving needs and expectations.	Passenger
TDR6 HDD Unmounted	The TOD will display a message when the TDR6 HDD is unmounted to assist maintenance, troubleshooting, and verifying readiness for service for all 219 Vehicles .	Operations/ Maintenance
Corner Hatch additional retention clips	The Corner Hatch will be modified to prevent it from quickly opening when unlocked for all 219 Vehicles.	Operations/ Maintenance
Replace door touch strips with passenger door open PBs	On 151 Phase 2 vehicles only, each doorway shall have 'keep door open' push buttons instead of the touch strips	Passenger

# Contract Mod. 7 Items (cont'd.)

Update	Description	Team
Push to Close locking feature addition to exterior EDR door	The Exterior Manual Emergency Door Release access panel when include a locking feature when pushed closed for all 219 Vehicles.	Operations/ Maintenance
Pre Wiring for Additional Clipper card readers	Wiring for additional Clipper card readers will be included on 151 Phase 2 Vehicles.	Passenger/ Operations
Provisions for ease of tire replacement	Wheel hubs specified in this change will be designed with a hole pattern for easier tire replacement and use with shop equipment on 151 Phase 2 Vehicles.	Maintenance
PIS 40 A pattern change	The Passenger Information System will be modified to allow remote and manual changes to information displays at any time.	Passenger/ Maintenance

# LRV4 Funding plan

Funding Source	Amount
Prop K Sales Tax	\$ 191,885,171
Revenue Bond	\$ 145,050,650
CCSF - Education Revenue Augmentation Fund (ERAF)	\$ 19,247,904
Regional Measure 3	\$ 7,122,556
Central Subway	\$ 16,800,000
SFMTA Operating	\$ 8,000,000
Federal Transit Administration (FTA)	\$ 526,875,814
Bridge Tolls (Metropolitan Transportation Commission)	\$ 79,838,236
Transit and Intercity Rail Capital Program (TIRCP)	\$ 113,140,000
ERAF or SFMTA Fund Balance	\$ 19,000,000
<b>Total</b>	<b>\$ 1,126,960,331</b>